



深圳市国冶星光电子有限公司
SHENZHEN GUOYEXING OPTOELECTRONICS CO.,LTD.

承认书

SPECIFICATION FOR APPROVAL

客户名称Customer: _____

产品型号Model: GYXS-5161AB

企业号No.: GYX-G-003

客户号Customer No: DDCG0289

日期Date: 2008-06-24

附产品规格书Enclosure is the specification

深圳市国冶星光电子有限公司 SHENZHEN GUOYEXING OPTOELECTRONICS CO.,LTD.			
生产部 Production Dept.	质量部 Quality Dept.	工程部 Engineering Dept.	市场部 Marketing Dept.
张述花 zhangshuhua	程斯容 chengsirong	廖晶晶 liaojingjing	韩丽娟 hanlijuan

客户确认签名 APPROVED SIGNATURES			

地址: 深圳市蛇口后海大道东角头工业区C座4楼 518067

Add: 4/F, Block C, Dongjiaotou Industrial Zone, Houhai Avenue, Shekou, Shenzhen.

电话Tel: 0086-755-26816353, 26816352

传真Fax: 0086-755-26686042

Email: gyx@gyx-led.com

Website: www.Gyx-led.com



GYXS-5161AB

PACKAGE DIMENSIONS

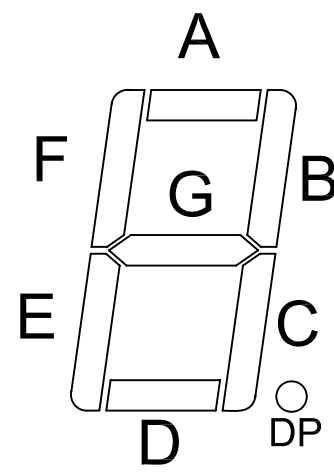
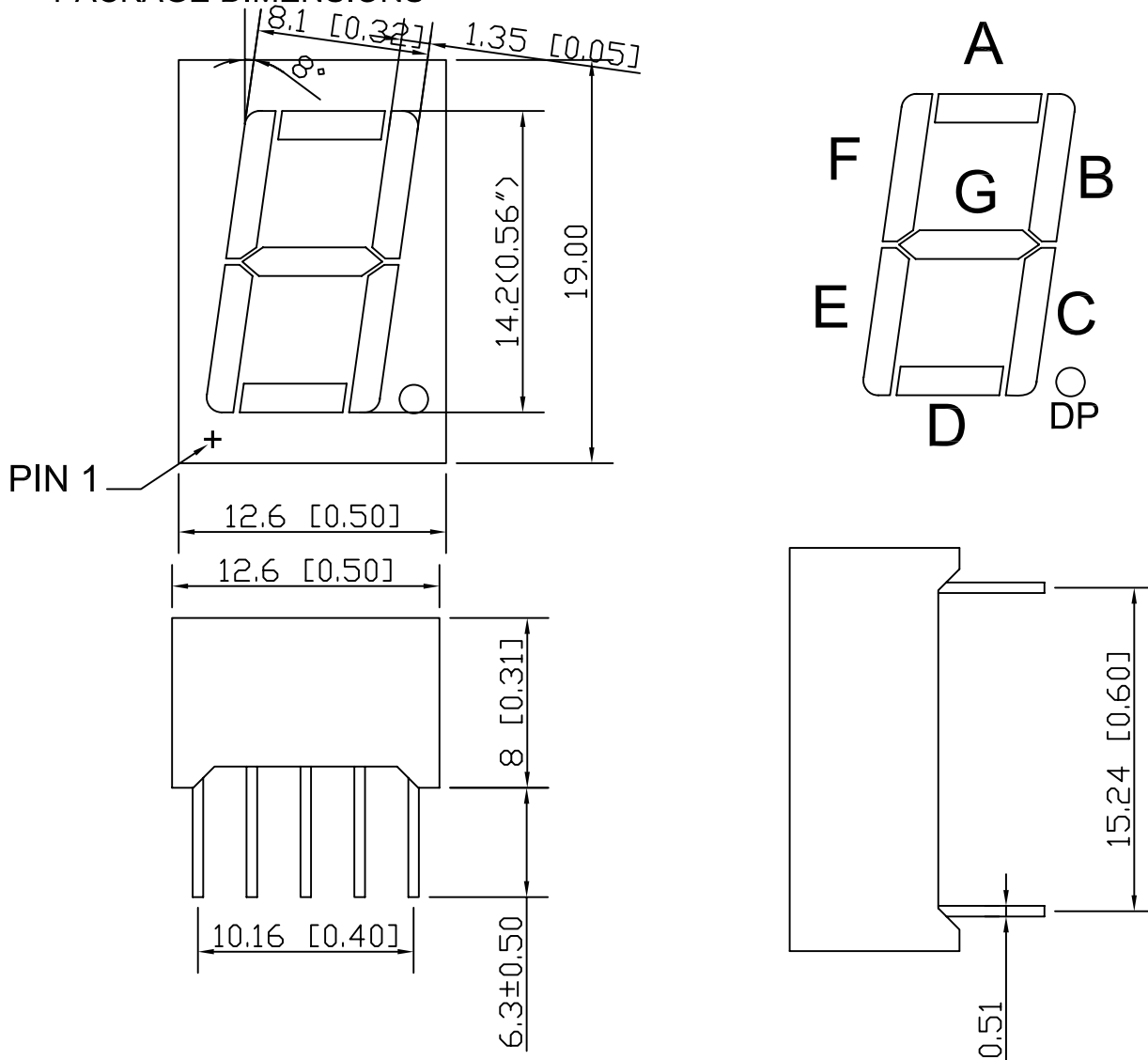

INTERNAL CIRCUIT DIAGRAM

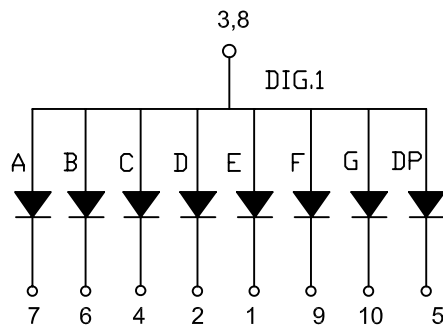

Notes:

- 1. All dimensions are in millimeters (inch), Tolerance is $\pm 0.25\text{mm}$ ($0.01''$) unless otherwise noted.
- 2. The specification may be changed without notice.



General Information

Part NO.	Chip Material	Emitting Color	Lens Type	Description
GYXS-5161AB	InGaN	BLUE	Diffused	Common Anode

Electrical/Optical Characteristics at Ta=25°C

Parameter	Symbol	Typ.	Max.	Unit	Conditions
Luminous Intensity	I _v	140	160	mcd	I _F =20mA
Peak Wavelength	λ _P	—	—	nm	I _F =20mA
Dominant Wavelength	λ _D	465	467.5	nm	I _F =20mA
Spectral Line Half-Width	Δλ	—	22	nm	I _F =20mA
Forward Voltage	V _F	3.0	3.5	V	I _F =20mA
Reverse Current	I _R	—	50	uA	V _R =5V

Absolute Maximum Ratings at Ta=25°C

Parameter	Symbol	Maximum Rating	Unit
Power Dissipation	P _d	65	mW
Forward Current	I _F	20	mA
Peak Forward Current(1)	I _F (Peak)	120	mA
Reverse Voltage	V _R	5	V
Operating Temperature	T _{opr}	-40° c+80° c	
Storage Temperature	T _{stg}	-40° c+80° c	
Lead Solder Temperature(2)	T _{sol}	260° c for 5 seconds	

Notes:

- 1/10 duty cycle, 0.1ms pulse width.
- 2mm below package base.